

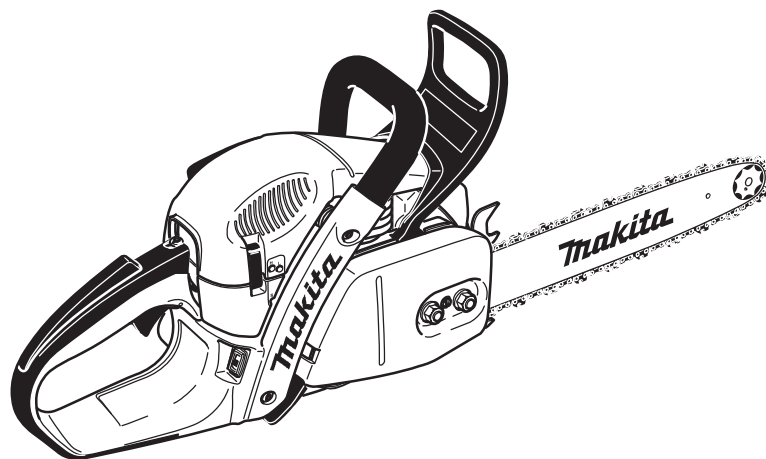

Instruction Manual

Original Instruction Manual

toolsupgrade.com



DCS4630
DCS5030
DCS5031
DCS5032



Important:

Read this instruction manual carefully before putting the chain saw into operation and strictly observe the safety regulations!

Keep this instruction manual!

Thank you for purchasing a MAKITA product!

Congratulations on choosing a MAKITA chain saw! We are confident that you will be satisfied with this modern piece of equipment. The DCS4630, DCS5030, DCS5031 and DCS5032 are very handy and robust chain saws with a new Design.

The automatic chain lubrication with variable-flow oil pump and maintenance-free electronic ignition ensure trouble-free operation, while the hand-saving anti-vibration system and ergonomic grips and controls make work easier, safer, and less tiring for the user.

The Featherlight-Start system lets you start the saw effortlessly with a spring-loaded starting assist.

MAKITA chain saws DCS4630, DCS5030, DCS5031 and DCS5032 are equipped with the latest safety features and meet all national and international standards. These features include: hand guards on both handles, grip throttle lever lock, chain catch, safety saw chain, and chain brake. The chain brake can be actuated manually, and is also inertia-actuated automatically in case of kickback.

The following industrial property rights apply: DE 10191359, WO 01/77572, DE 20006638, US 7033149, DE 20219246, US 7204025, EP 1428637, DE 20013210, US 6648161, DE 10132973, DE 10202360, DE 20102076, US 6814192, DE 20314982, US 7191751, DE 10157589, DE 20021316, US 6578543.

In order to ensure the proper functioning and performance of your new chain saw, and to safeguard your own personal safety, it is imperative that you read this instruction manual thoroughly before operation. Be especially careful to observe all safety precautions! Failure to observe these precautions can lead to severe injury or death!



Table of contents	Page
Packing	2
Delivery inventory	3
Symbols	3
SAFETY PRECAUTIONS	
General precautions	4
Protective equipment	4
Fuels / Refuelling	5
Putting into operation	5
Kickback	6
Working behavior/Method of working	6-7
Transport and storage	8
Maintenance	8
First aid	8
Technical data	9
Nomination of components	9
PUTTING INTO OPERATION	
Mounting the guide bar and saw chain	10-11
Tightening the saw chain	11
Checking the chain tension	12
Retightening the saw chain	12
Chain brake	12
Fuels	13-14
Refuelling	14
Checking the chain lubrication	15
Adjusting the chain lubrication	15
Starting the engine	16
Cold start	16
Warm start	16
Stopping the engine	16
Checking the chain brake	16
Working in winter	17
Grip heating	17
Adjusting the carburetor	18
MAINTENANCE	
Sharpening the saw chain	19-20
Cleaning the brake band and sprocket interior	21
Cleaning the guide bar	21
Replacing the saw chain	22
Cleaning the air filter	23
Replacing the spark plug	24
Checking the ignition spark	24
Checking the muffler screws	24
Replacing the starter cable / Replacing the return spring / Replacing the Featherlight-Start spring	25
Mounting the fan housing	25
Cleaning the cylinder area	26
Replacing the suction head	26
Instructions for periodic maintenance	27
Service, spare parts and guarantee	28
Trouble shooting	29
EU conformity declaration	29
Extract from spare parts list	30-31
Accessories	30-31

Packing

Your MAKITA chain saw comes delivered in a protective cardboard box to protect against shipping damage.

Cardboard is a basic raw material and is consequently reuseable or suitable for recycling (waste paper recycling).



Delivery inventory

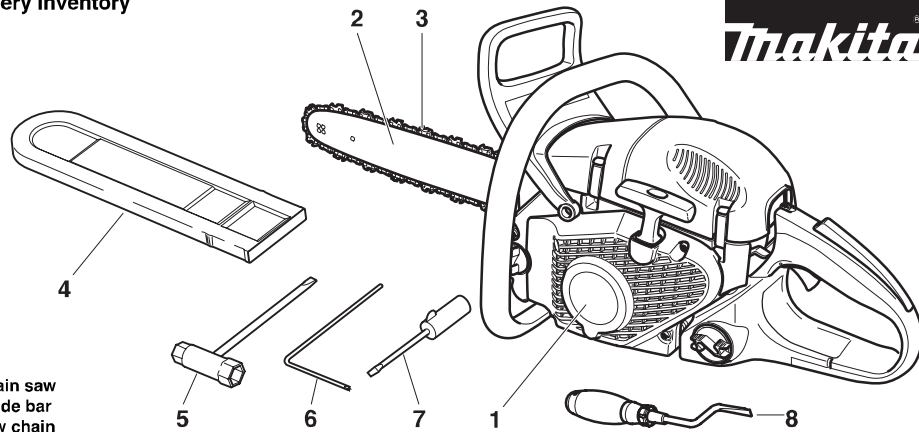























1. Chain saw
2. Guide bar
3. Saw chain
4. Chain protection cover
5. Universal wrench
6. Offset screwdriver
7. Screwdriver for carburetor adjustment
8. Cylinder fin cleaner
9. Instruction manual (not shown)

In case one of the parts listed should not be included in the delivery inventory, please consult your sales agent.

Symbols

You will notice the following symbols on the saw and in the Instruction Manual:

	Read instruction manual and follow the warning- and safety precautions!		Caution, kickback!
	Particular care and caution!		Chain brake
	Forbidden!		Fuel and oil mixture
	Wear protective helmet, eye and ear protection!		Normal / Winter operation
	Wear protective gloves!		Grip heating
	No smoking!		Carburetor adjustment
	No open fire!		Chain oil fill/oil pump
	Stop engine!		Saw chain oil adjustment screw
	Push decompression valve		First aid
	Start engine		Recycling
	Combination switch Start/Stop (I/O), Choke		CE - Marking
	Safety position		

SAFETY PRECAUTIONS

Intended use

Power chain saws

This power chain saw may be used only for sawing wood out of doors. It is intended for the following uses depending on its class:

- **Professional and mid-class:** Use on small, medium and large trees: felling, limb removal, cutting to length, thinning.
- **Hobbyklasse:** Occasional use on small trees, fruit-tree care, felling, limb removal, cutting to length.

Unauthorised users:

Persons who are not familiar with the Instruction Manual, children, young people, and persons under the influence of drugs, alcohol or medication must not use this saw.

- **Protective gloves (6)** made of thick leather are part of the prescribed equipment and must always be worn during operation of the chain saw.
- During operation of the chain saw **safety shoes or safety boots (7)** fitted with anti skid sole, steel toe caps and protection for the leg must always to be worn. Safety shoes equipped with a protective layer provide protection against cuts and ensure a secure footing.

General precautions

- **To ensure correct operation the user has to read this instruction manual** to make himself familiar with the characteristics of the chain saw. Users insufficiently informed will endanger themselves as well as others due to improper handling.
- It is recommended to lend the chain saw only to people who are experienced in working with chain saws. Always hand over the instruction manual.
- First users should ask the dealer for basic instructions to become familiarized with the characteristics of engine powered sawing or even attend a recognized course of instruction.
- Children and young persons aged under 18 years must not be allowed to operate the chain saw. Persons over the age of 16 years may, however, use the chain saw for the purpose of being trained as long as they are under the supervision of a qualified trainer.
- Use chain saws always with the utmost care and attention.
- Operate the chain saw only if you are in good physical condition. If you are tired, your attention will be reduced. Be especially careful at the end of a working day. Perform all work calmly and carefully. The user has to accept liability for others.
- Never use the chain saw after having consumed alcohol, drugs or medication.
- A fire extinguisher must be available in the immediate vicinity when working in easily inflammable vegetation or when it has not rained for a long time (danger of fire).

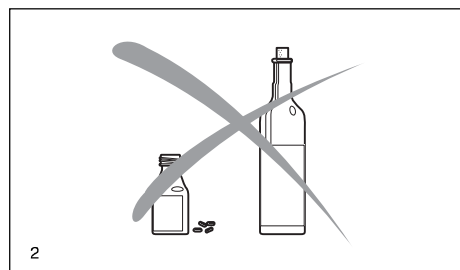

Protective equipment

- **In order to avoid head, eye, hand or foot injuries as well as to protect your hearing the following protective equipment must be used during operation of the chain saw:**
- The kind of clothing should be appropriate, i. e. it should be tight-fitting but not be a hindrance. Do not wear jewellery or clothing which could become entangled with bushes or shrubs. If you have long hair, always wear a hairnet!
- It is necessary to wear a protective helmet whenever working with the chain saw. The **protective helmet (1)** is to be checked in regular intervals for damage and is to be replaced after 5 years at the latest. Use only approved protective helmets.
- The **face shield (2)** of the protective helmet (or the goggles) protects against sawdust and wood chips. During operation of the chain saw always wear a goggle or a face shield to prevent eye injuries.
- Wear adequate **noise protection equipment** (ear muffs (3), ear plugs, etc.). Octave brand analysis upon request.
- The **safety jacket (4)** is provided with special signal-coloured shoulder straps and is comfortable and easy to care for.
- The **protective brace and bib overall (5)** is made of a nylon fabric with 22 layers and protects against cuts. We strongly recommend its use.

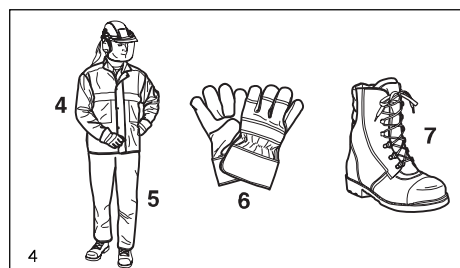
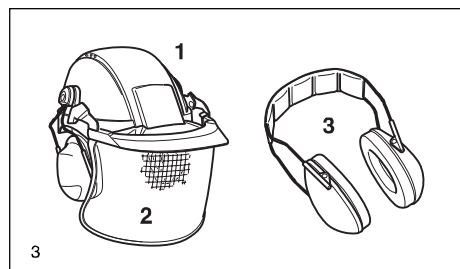

Fuels / Refuelling

- Stop the engine before refuelling the chain saw.
- Do not smoke or work near open fires (5).
- Let the engine cool down before refuelling.
- Fuels can contain substances similar to solvents. Eyes and skin should not come in contact with mineral oil products. Always wear protective gloves when refuelling. Frequently clean and change protective clothes. Do not breathe in fuel vapors. Inhalation of fuel vapours can be hazardous to your health.
- Do not spill fuel or chain oil. When you have spilt fuel or oil immediately clean the chain saw. Fuel should not come in contact with clothes. If your clothes have come in contact with fuel, change them at once.
- Ensure that no fuel or chain oil oozes into the soil (environmental protection). Use an appropriate base.
- Refuelling is not allowed in closed rooms. Fuel vapors will accumulate near the floor (explosion hazard).
- Ensure to firmly tighten the screw plugs of the fuel and oil tanks.
- Change the place before starting the engine (at least 3 m from the place of refuelling) (6).
- Fuel cannot be stored for an unlimited period of time. Buy only as much as will be consumed in the near future.
- Use only approved and marked containers for the transport and storage of fuel and chain oil. Ensure children have no access to fuel or chain oil.

Putting into operation

- **Do not work on your own. Another person must be nearby in case of emergencies** (within shouting distance).
- Ensure that there are no children or other people within the working area. Pay attention to any animals in the working area, as well (7).
- **Before starting work the chain saw must be checked for perfect function and operating safety according to the prescriptions.**
Check especially the function of the chain brake, the correct mounting of the guide bar, the correct sharpening and tightening of the chain, the firm mounting of the sprocket guard, the easy motion of the throttle lever and the function of the throttle lever lock, the cleanliness and dryness of the handles, and the function of the ON/OFF switch.
- Put the chain saw only into operation if it is completely assembled. Never use the chain saw when it is not completely assembled.
- Before starting the chain saw ensure that you have a safe footing.
- Put the chain saw into operation only as described in this instruction manual (8). Other starting methods are not allowed.
- When starting the chain saw it must be well supported and securely held. The guide bar and chain must not be in contact with any object.
- **When working with the chain saw always hold it with both hands.** Take the back handle with the right hand and the tubular handle with the left hand. Hold the handles tightly with your thumbs facing your fingers.
- **CAUTION: When releasing the throttle lever the chain will keep on running for a short period of time** (free-wheeling).
- Continuously ensure that you have a safe footing.
- Hold the chain saw such that you will not breathe in the exhaust gas. Do not work in closed rooms (danger of poisoning).
- **Switch off the chain saw immediately if you observe any changes in its operating behavior.**
- **The engine must be switched off before checking the chain tension, tightening the chain, replacing it or clearing malfunctions** (9).
- When the sawing device is hit by stones, nails or other hard objects, switch off the engine immediately and check the sawing device.
- When stopping work or leaving the working place switch off the chain saw (9) and put it down such that nobody is endangered.
- Do not put the overheated power chain saw in dry grass or on any inflammable objects. The muffler is very hot (danger of fire).
- **CAUTION: Oil dropping from the chain or guide bar after having stopped the saw chain will pollute the soil. Always use an appropriate base.**



5

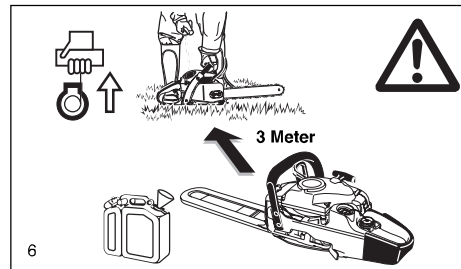

6

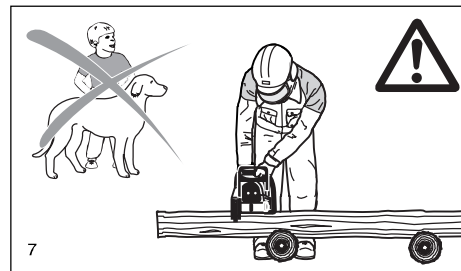

7

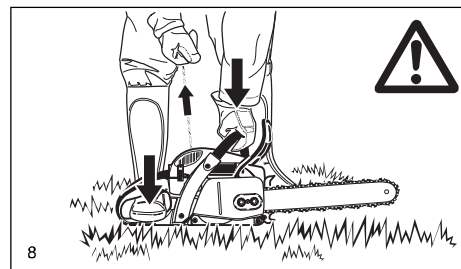

8

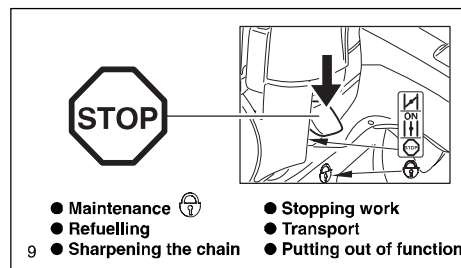

9

Kickback

- When working with the chain saw dangerous kickbacks may occur.
- Kickback occurs when the upper part of the end of the guide bar inadvertently touches wood or other hard objects (10).
- This causes the saw to be thrown back toward the user with great force and out of control. **Risk of injury!**

In order to prevent kickback, follow these rules:

- Only specially-trained persons should perform plunge cuts, i.e., piercing timber or wood with the tip of the saw!
- Never apply the end of the bar when starting to make a cut.
- Always observe the end of the guide bar. Be careful when continuing an already started cut.
- When starting to cut the chain must be running.
- Ensure that the chain is always sharpened correctly. Pay special attention to the height of the depth limiter.
- Never cut several branches at the same time. When cutting a branch ensure that no other branch is touched.
- When crosscutting a trunk be aware of the trunks next to it.

Working behavior/Method of working

- Only use the chain saw during good light and visibility periods. Be aware of slippery or wet areas, and of ice and snow (risk of slipping). The risk of slipping is extremely high when working on recently peeled wood (bark).
- Never work on unstable surfaces. Make sure that there are no obstacles in the working area, risk of stumbling. Always ensure that you have a safe footing.
- Never saw above your shoulder height (11).
- Never saw while standing on a ladder (11).
- Never climb up into trees to perform sawing with the chain saw.
- Do not work leaning too far over.
- Guide the chain saw in such a way that no part of your body is within the elongated swivelling range of the saw (12).
- Use the chain saw for sawing wood only.
- Avoid touching the ground with the chain saw while it is still running.
- Never use the chain saw for lifting up or removing pieces of wood or other objects.
- Remove foreign objects such as sand, stones and nails found within the working area. Foreign objects may damage the sawing device and can cause dangerous kickback.
- When sawing pre-cut timber use a safe support (sawing jack, 13). Do not steady the workpiece with your foot, and do not allow anyone else to hold or steady it.
- Secure round pieces against rotation.

- **For cutting down trees or performing crosscuts the spike bar (13, Z) must be applied to the wood to be cut.**
- Before performing a **crosscut** firmly apply the spike bar to the timber, only then can the timber be cut with the chain running. For this the chain saw is lifted at the back handle and guided with the tubular handle. The spike bar serves as a centre of rotation. Continue by slightly pressing down the tubular handle and simultaneously pulling back the chain saw. Apply the spike bar a little bit deeper and once again lift the back handle.
- **When the timber must be pierced for cutting or longitudinal cuts are to be performed it is urgently recommended to have this carried out by specially trained persons only** (high risk of kickback).
- Do **longitudinal - lengthwise - cuts** at the lowest possible angle (14). Be very careful when doing this type of cut, as the spike bar cannot grip.
- The saw must be running whenever you remove the chain saw from the wood.
- When performing several cuts the throttle lever must be released in between.

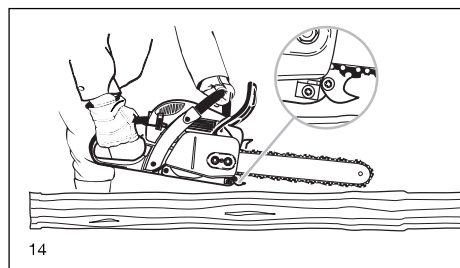
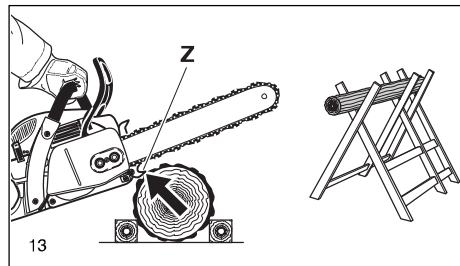
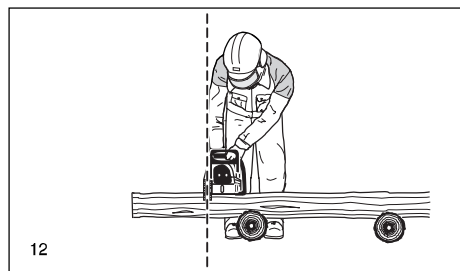
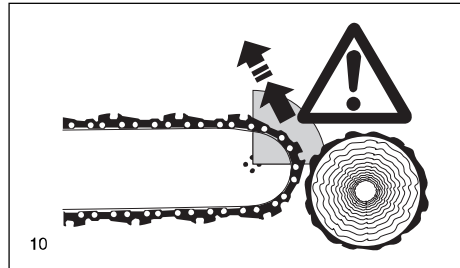

- Be careful when cutting splintery wood. Cut pieces of wood may be pulled along (risk of injuries).
- When cutting with the upper edge of the guide bar, the chain saw may be pushed in the direction of the user if the chain gets clamped. For this reason use the lower edge of the bar whenever possible. The chain saw will then be pushed away from you (15).
- If the timber is under tension (16), first cut the pressure side (A). Then the crosscut can be performed on the tension side (B). Thus clamping of the guide bar can be avoided.

CAUTION:

People felling trees or cutting of branches must be specially trained. High risk of injuries!

- When cutting of branches, the chain saw should be supported on the trunk. Do not use the end of the bar for cutting (risk of kickback).
- Be aware of branches under tension. Do not cut free branches from below.
- Never perform detensioning cuts while standing on the trunk.
- **Before cutting down a tree ensure that**
 - a) only those people are within the working area which are actually involved in cutting down the tree.
 - b) every worker involved can withdraw without stumbling (the people should withdraw backwards in a diagonal line, i. e. at a degree of 45°).
 - c) the bottom part of the trunk is free from foreign objects, underbrush and branches. Make sure to have a safe footing (risk of stumbling).
 - d) the next working place is at least 2 1/2 tree lengths away (17). Before cutting down the tree check the direction of fall and make sure that there are neither people nor objects within a distance of 2 1/2 tree lengths.

Judging the tree:

Direction of hanging - loose or dry branches - height of the tree - natural overhang - is the tree rotten?

- Take into account the direction and speed of the wind. If strong gusts are occurring, do not do any felling.
- **Cutting the roots:**
Start with the strongest root. First do the vertical and then the horizontal cut.
- **Notching the trunk (18, A):**
The notch determines the direction of fall and guides the tree. The trunk is notched perpendicular to the direction of fall and penetrates 1/3 - 1/5 of the trunk diameter. Perform the cut near the ground.
- When correcting the cut, always do so over the whole width of the notch.
- **Cut down the tree (19, B)** above the bottom edge of the notch (D). The cut must be exactly horizontal. The distance between both cuts must be approx. 1/10 of the trunk diameter.
- **The material between both cuts (C)** serves as a hinge. Never cut it through, otherwise the tree will fall without any control. Insert felling wedges in time.
- Secure the cut only with wedges made of plastic or aluminium. Do **not** use iron wedges. If the saw hits an iron wedge the chain can be seriously damaged or torn.
- When cutting down a tree always stay sideways of the falling tree.
- When withdrawing after having performed the cut, be alert for falling branches.
- When working on sloping ground the user of the chain saw must stay above or sideways of the trunk to be cut or the tree already cut down.
- Be alert for trunks which may roll towards you.

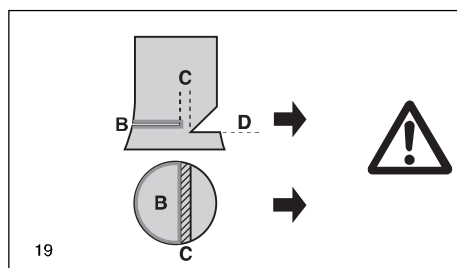
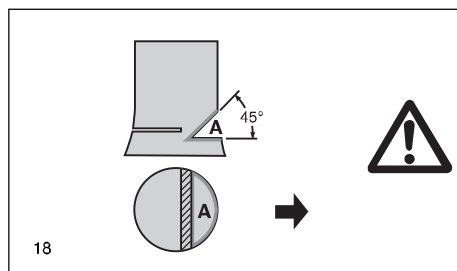
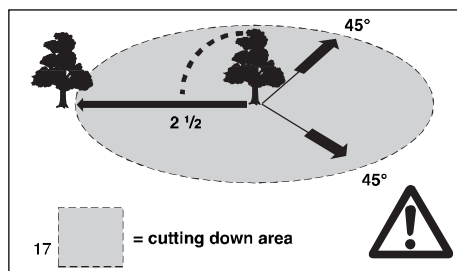
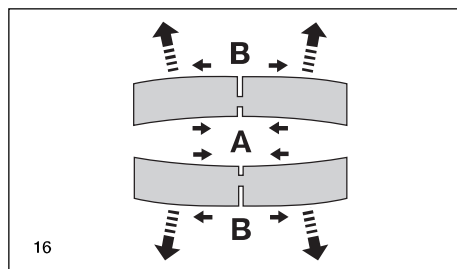
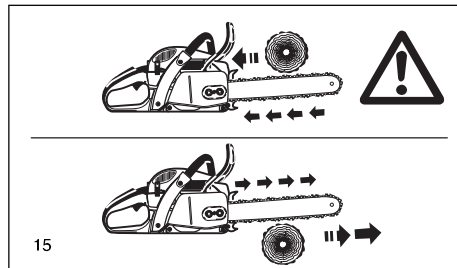

Transport and storage

- When changing your location during work switch off the chain saw and actuate the chain brake in order to prevent an inadvertent start of the chain.
- Never carry or transport the chain saw with the chain running.
- When transporting the chain saw over long distances the guide bar protection cover (delivered with the chain saw) must be applied.
- Carry the chain saw with the tubular handle. The guide bar points backwards (20). Avoid coming in contact with the muffler (danger of burns).
- Ensure safe positioning of the chain saw during car transportation to avoid fuel or chain oil leakage.
- Store the chain saw safely in a dry place. It must not be stored outdoors. Keep the chain saw away from children.
- Before storing the chain saw over a long period of time or shipping it the fuel and oil tanks must be completely emptied.

Maintenance

- **Before performing maintenance work switch off the chain saw (21) and pull out the plug cap.**
- Before starting work always check the operating safety of the chain saw, in particular the function of the chain brake. Make sure that the chain is always sharpened and tightened correctly (22).
- Operate the chain saw only at a low noise and emission level. For this ensure the carburetor is adjusted correctly.
- Regularly clean the chain saw.
- Regularly check the tank cap for tightness.

Observe the accident prevention instructions issued by trade associations and insurance companies. Do not perform any modifications on the chain saw. You will put your safety at risk.

Perform only the maintenance and repair works described in the instruction manual. All other work must be carried out by MAKITA Service.

Use only original MAKITA spare parts and accessories.

Using spare parts other than original MAKITA parts or accessories and guide bar/chain combinations or lengths which are not approved bring a high risk of accidents. We cannot accept any responsibility for accidents and damage resulting from using sawing devices or accessories which have not been approved.

First aid

For the event of a possible accident, please make sure that a first aid kit is always immediately available close by. Immediately replace any items used from the first aid box.

When calling for help, give the following information:

- Place of the accident
- What happened
- Number of injured people
- Kind of injuries
- Your name!

NOTE

Individuals with poor circulation who are exposed to excessive vibration may experience injury to blood vessels or the nervous system.

Vibration may cause the following symptoms to occur in the fingers, hands or wrists: "Falling asleep" (numbness), tingling, pain, stabbing sensation, alteration of skin colour or of the skin. **If any of these symptoms occur, see a physician!**

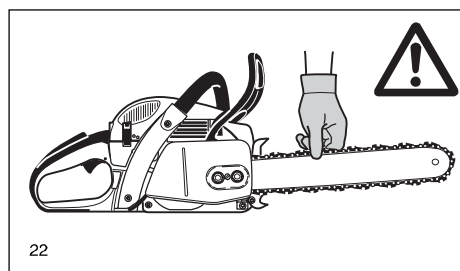
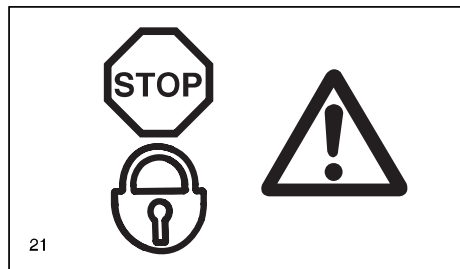
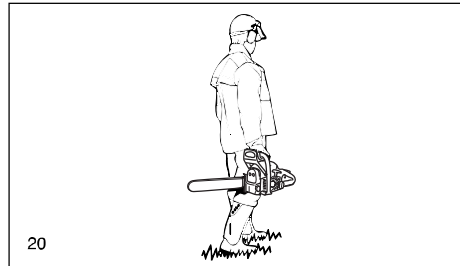

Technical data

		DCS4630	DCS5030, 5031, 5032
Stroke volume	cm ³	45.6	50.0
Bore	mm	43	45
Stroke	mm	31.4	31.44
Max. power at speed ²⁾	kW / 1/min	2.6 / 10,000	2.8 / 10,000
Max. torque at speed ²⁾	Nm / 1/min	2.8 / 7,000	3.1 / 7,000
Idling speed / max. engine speed with bar and chain	1/min	2,500 / 13,800	2,500 / 13,800
Clutch engagement speed	1/min	3,900	3,900
Sound pressure level at the workplace L _{WA, eq} per ISO/CD 22868 ¹⁾³⁾	dB(A)	101,2 / K _{WA} = 2,5	101 / K _{WA} = 2,5
Sound power level L _{WA, eq} per ISO/CD 22868 ¹⁾³⁾	dB(A)	109,1 / K _{WA} = 2,5	108,6 / K _{WA} = 2,5
Vibration acceleration a _{w, eq} per ISO 22867 ¹⁾³⁾			
- Tubular handle	m/s ²	4,1 / K = 2	5,2 / K = 2
- Rear handle	m/s ²	3,6 / K = 2	3,7 / K = 2
Carburetor Carburetor (membrane, choke valve carburetor)	Type	ZAMA	
Ignition system	Type	electronic	
Spark plug	Type	NGK BPRM 7A	
Electrode gap	mm	0.5	
or spark plug	Type	BOSCH WSR 6F	
Fuel consumption at max. load per ISO 7293 ²⁾	kg/h	1.2	1.3
Specific consumption at max. load per ISO 7293 ²⁾	g/kWh	450	450
Fuel tank capacity	l	0.47	
Chain oil tank capacity	l	0.27	
Mixture ratio (fuel/two-stroke oil)		50 : 1	
- when using MAKITA oil		50 : 1 (2%)	
- when using Aspen Alkylat (two-stroke fuel)		50 : 1 (quality grade: JASO FC or ISO EGD)	
- when using other oils		50 : 1 (quality grade: JASO FC or ISO EGD)	
Chain brake		engages manually or in case of kickback	
Chain speed (at max. power)	m/s	19,3 / 22,2	19,3 / 22,2
Sprocket pitch	inch	.325 oder 3/8	
Number of teeth	Z	7	
Chain type		see the Extract from the spare-parts list	
Pitch / gauge	inch	.325 / 0,050, 0,058 or 3/8 / 0,058	
Guide bar, length of a cut	cm	33 / 38 / 45 / 53	
Guide-bar type		see the Extract from the spare-parts list	
Weight (fuel tank empty, without chain, guide bar and accessories) kg		5.1	5.1

¹⁾ Figures derived in equal part from idling, full-load and racing speed.

²⁾ For models without starting valve.

³⁾ Uncertainty (K=).

Denomination of components

- 1 Handle
- 2 Cover
- 3 Cover clasp
- 4 Tubular handle
- 5 Hand guard (release for chain brake)
- 6 Muffler
- 7 Spike bar
- 8 Chain tensioning screw
- 9 Retaining nuts
- 10 Chain catch
- 11 Sprocket guard
- 12 Decompression valve (only on "DCS5031" model saws)
- 13 Adjusting screw for oil pump (bottom side)
- 14 Adjusting screws for carburetor
- 15 Switch for grip heating (only on "DCS5032" model saws)
- 16 Identification plate
- 17 Starter grip
- 18 Combination switch (Choke / Start / Stop)
- 19 Throttle lever
- 20 Safety locking button
- 21 Rear hand guard
- 22 Fuel tank cap
- 23 Fan housing with starting assembly
- 24 Oil tank cap
- 25 Guide bar
- 26 Chain (Blade)

Identification plate (16)

Indicate when ordering spare parts



Serial number
Year of manufacture

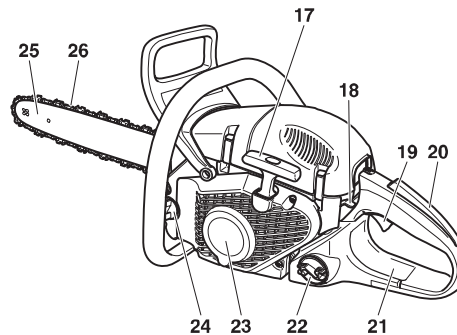
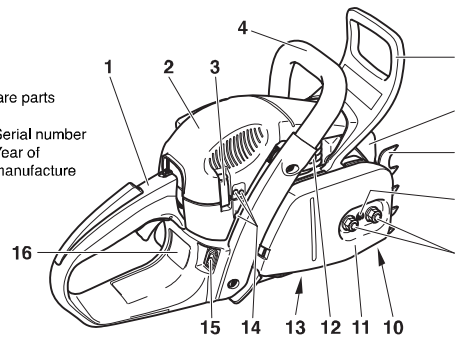



PUTTING INTO OPERATION

CAUTION:
 Before doing any work on the guide bar or chain, always switch off the engine and pull the plug cap off the spark plug (see „Replacing the spark plug“). Always wear protective gloves!

CAUTION:
 Start the chain saw only after having assembled it completely and inspected.

A

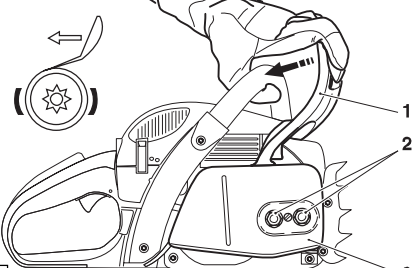

Mounting the guide bar and saw chain

Use the universal wrench delivered with the chain saw for the following work.

Put the chain saw on a stable surface and carry out the following steps for mounting the guide bar and saw chain:

Release the chain brake by pulling the hand guard (1) in direction of arrow.

Unscrew retaining nuts (2).

Pull off the sprocket guard (3).

B

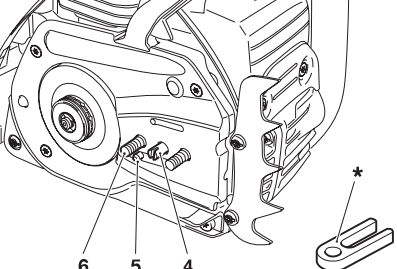

Remove the plastic transport cover (*) and dispose of properly.

Turn chain tensioning screw (4) to the left (counter-clockwise) until the pin (5) of the chain tensioner is underneath the threaded pin (6).

C

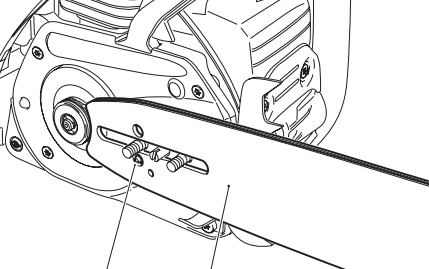

Put on the guide bar (7). Make sure that the pin (5) of the chain tensioner engages in the hole in the guide bar.

D

Lift the chain (9) over the sprocket (8).

CAUTION:

Do not insert the chain **between the chain sprocket and the disc.**

Guide the chain from above about halfway into the groove (10) on the guide bar.

Place the chain over the chain catch (11) on the bottom.

CAUTION:

Note that the cutting edges along the top of the chain must point in the direction of the arrow!

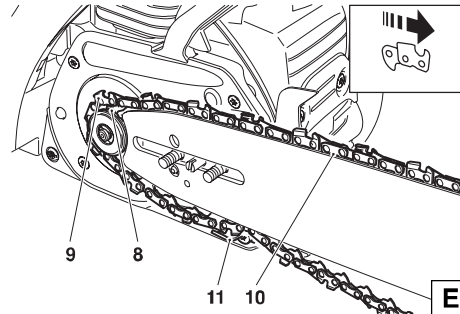

Pull the chain (9) around the sprocket nose (12) of the guide bar in the direction of the arrow.

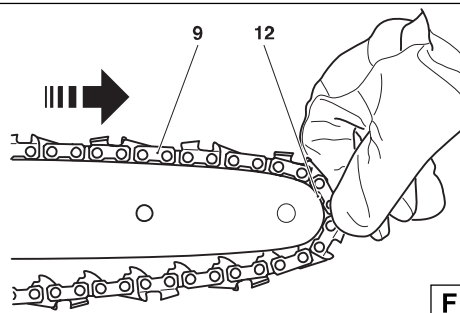

Replace the sprocket guard (3).

Tighten the nuts (2) only hand-tight to begin with.

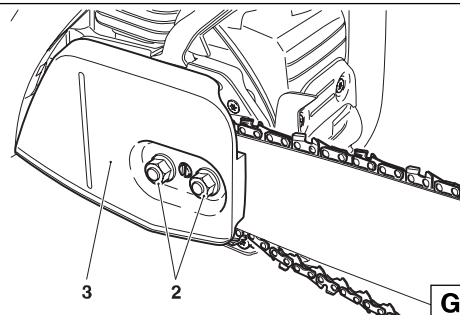

Tightening the saw chain

Turn the chain tensioning screw (4) to the right (clockwise) until the saw chain catches in the groove on the lower side of the guide bar (see circle).

Slightly lift the end of the guide bar and turn the chain adjusting screw (4) to the right (clockwise) until the chain rests against the bottom side of the guide bar.

While still holding up the tip of the guide bar, tighten the retaining nuts (2) with the universal wrench.

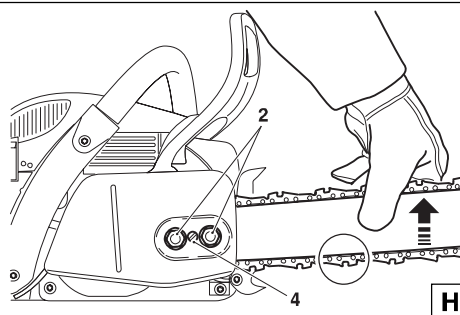

Checking the chain tension

The tension of the chain is correct if the chain rests against the bottom side of the guide bar and can still be easily turned by hand.

While doing so the chain brake must be released.

Check the chain tension frequently - new chains tend to get longer during use!

When checking the chain tension the engine must be switched off.

NOTE:

It is recommended to use 2-3 chains alternatively.

In order to guarantee uniform wear of the guide bar the bar should be turned over whenever replacing the chain.

Chain brake

The DCS4630, DCS5030, DCS5031 and DCS5032 comes with an inertia chain brake as standard equipment. If kickback occurs due to contact of the guide-bar tip with wood (see SAFETY PRECAUTIONS, page 6), the chain brake will stop the chain through inertia if the kickback is sufficiently strong.

The chain will stop within a fraction of a second.

The chain brake is installed to block the saw chain before starting it and to stop it immediately in case of an emergency.

IMPORTANT: NEVER run the saw with the chain brake activated (except for testing, see "Testing chain brake")! Doing so can very quickly cause extensive engine damage!

ALWAYS release the chain brake before starting the work!

Engaging the chain brake (braking)

If the kickback is strong enough the sudden acceleration of the guide bar combined with the inertia of the hand guard (1) will **automatically** actuate the chain brake.

To engage the chain brake **manually**, simply push the hand guard (1) forward (towards the tip of the saw) with your left hand (arrow 1).

Releasing the chain brake

Pull the hand guard (1) towards you (arrow 2) until you feel it catch. The brake is now released.

Fuel

CAUTION:

This saw is powered by mineral-oil products (gasoline and oil).

Be especially careful when handling gasoline.

Do not smoke. Keep tool well away from open flames, spark, or fire (explosion hazard).

Fuel mixture

This tool is powered by a high-performance air-cooled two-stroke engine. It runs on a mixture of gasoline and two-stroke engine oil.

The engine is designed for unleaded regular gasoline with a min. octane value of 91 ROZ. In case no such fuel is available, you can use fuel with a higher octane value. This will not affect the engine.

In order to obtain an optimum engine output and to protect your health and the environment use unleaded fuel only.

To lubricate the engine, use a synthetic oil for two-stroke air-cooled engines (quality grade JASO FC or ISO EGD), which has to be added to the fuel. The engine has been designed for use of MAKITA high-performance two-stroke engine oil and a mixture ratio of only 50:1 to protect the environment. In addition, a long service life and reliable operation with a minimum emission of exhaust gases are ensured.

MAKITA high-performance two-stroke engine oil is available in the following sizes to suit your individual requirements:

1 l	order number 980 008 607
100 ml	order number 980 008 606

In case MAKITA high-performance two-stroke engine oil is not available, it is urgently recommended to use a mixture ratio of 50:1 with other two-stroke engine oils, as otherwise optimum operation of the engine cannot be guaranteed.

 **Caution: Do not use ready-mixed fuel from petrol stations.**

The correct mixture ratio:

50:1 when using MAKITA high-performance two-stroke engine oil, i. e. mix 50 parts gasoline with 1 part oil.

50:1 when using other synthetic two-stroke engine oils (quality grade JASO FC or ISO EGD), i. e. mix 50 parts gasoline with 1 part oil.

NOTE:

For preparing the fuel-oil mixture first mix the entire oil quantity with half of the fuel required, then add the remaining fuel.

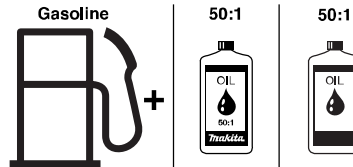

Gasoline	50:1	50:1
1000 cm ³ (1 litre)	20 cm ³	20 cm ³
5000 cm ³ (5 litres)	100 cm ³	100 cm ³
10000 cm ³ (10 litres)	200 cm ³	200 cm ³

Thoroughly shake the mixture before filling it into the chain saw tank.

It is not wise to add more engine oil than specified to ensure safe operation. This will only result in a higher production of combustion residues which will pollute the environment and clog the exhaust channel in the cylinder as well as the muffler. In addition, fuel consumption will rise and performance will decrease.

The Storage of Fuel

Fuels have a limited storage life. Fuel and fuel mixtures age through evaporation, especially at high temperatures. Aged fuel and fuel mixtures can cause starting problems and damage the engine. Purchase only that amount of fuel, which will be consumed over the next few months. At high temperatures, once fuel has been mixed it should be used up in 6-8 weeks.

Store fuel only in proper containers, in dry, cool, secure locations!

AVOID SKIN AND EYE CONTACT

Mineral oil products degrease your skin. If your skin comes in contact with these substances repeatedly and for an extended period of time, it will desiccate. Various skin diseases may result. In addition, allergic reactions are known to occur.

Eyes can be irritated by contact with oil. If oil comes into your eyes, immediately wash them with clear water.

If your eyes are still irritated, see a doctor immediately!

D

Chain oil



Use an oil with adhesive additive for lubricating the chain and guide bar. The adhesive additive prevents the oil from being flung off the chain too quickly.

We recommend the use of chain oil which is bio-degradable in order to protect the environment. The use of bio-degradable oil may even be required by local regulations.

The chain oil BIOTOP sold by MAKITA is made of special vegetable oils and is 100% bio-degradable. BIOTOP has been granted the „blue angel“ (Blauer Umweltschutz-Engel) for being particularly environment-friendly (RAL UZ 48).



BIOTOP chain oil is available in the following sizes:

1 l	order number 980 008 610
5 l	order number 980 008 611

Bio-degradable oil is stable only for a limited period of time. It should be used within 2 years from the date of manufacture (printed on the container).

E

Important note on bio-degradable chain oils

If you are not planning to use the saw again for an extended period of time, empty the oil tank and put in a small amount of regular **engine oil** (SAE 30), and then run the saw for a time. This is necessary to flush out all remaining bio-degradable oil from the oil tank, oil-feed system, chain and guide bar, as many such oils tend to leave sticky residues over time, which can cause damage to the oil pump or other parts.

The next time you use the saw, fill the tank with BIOTOP chain oil again. In case of damage caused by using waste oil or inappropriate chain oil the product guarantee will be null and void.

Your salesman will inform you about the use of chain oil.

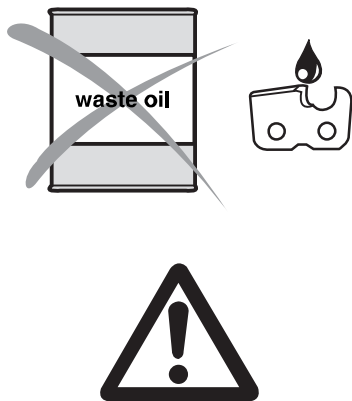

NEVER USE WASTE OIL

Waste oil is very dangerous for the environment.

Waste oil contains high amounts of carcinogenic substances. Residues in waste oil result in a high degree of wear and tear at the oil pump and the sawing device.

In case of damage caused by using waste oil or inappropriate chain oil the product guarantee will be null and void.

Your salesman will inform you about the use of chain oil.

AVOID SKIN AND EYE CONTACT

Mineral oil products degrease your skin. If your skin comes in contact with these substances repeatedly and for an extended period of time, it will desiccate. Various skin diseases may result. In addition, allergic reactions are known to occur.

Eyes can be irritated by contact with oil. If oil comes into your eyes, immediately wash them with clear water.

If your eyes are still irritated, see a doctor immediately!

A

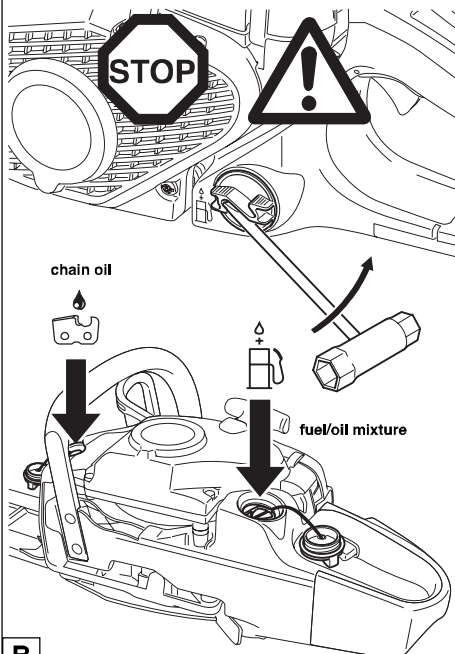

Refuelling



FOLLOW THE SAFETY PRECAUTIONS!

Be careful and cautious when handling fuels.

The engine must be switched off!

Thoroughly clean the area around the caps, to prevent dirt from getting into the fuel or oil tank.

Unscrew the tank cap (use the universal wrench if necessary, see illustration) and fill tank with fuel mixture or saw chain oil up to the bottom edge of the filling neck. Be careful not to spill fuel or chain oil! Be careful not to spill fuel or chain oil!

Screw on the tank cap **by hand all the way**.

Lubricating the chain



During operation there must always be sufficient chain oil in the chain-oil tank to provide good chain lubrication. One filling is sufficient for about one half-hour of continuous operation. During this procedure check whether there is enough the chain oil in the tank and refill if necessary. **Do this only with the engine turned off!** Screw on the tank cap **by hand all the way**.

B

Checking the chain lubrication

Never work with the chain saw without sufficient chain lubrication. Otherwise the service life of the chain and guide bar will be reduced. Before starting work check the oil level in the tank and the oil feed.

Check the oil feed rate as described below:

Start the chain saw (see „Starting the engine“).

Hold the running chain saw approx. 15 cm above a trunk or the ground (use an appropriate base).

If the lubrication is sufficient, you will see a light oil trace because oil will be flung off the sawing device. Pay attention to the direction the wind is blowing and avoid unnecessary exposure to the oil spray!

Note:

After the saw has been turned off it is normal for residual chain oil to drip from the oil feed system, the guide bar and the chain for a time. This does not constitute a defect!

Place the saw on a suitable surface.

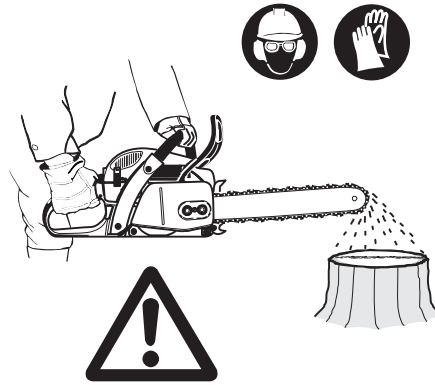

C

Adjusting the chain lubrication



The engine must be switched off.

You can adjust the oil pump feed rate with the adjusting screw (1). The adjusting screw is on the bottom side of the housing. The oil pump comes factory-set to a medium feed rate.

To adjust the supply rate, use a small screwdriver to turn the adjusting screw:

- to the right for a faster
- to the left for a slower oil feed rate.

Pick one of the three settings depending on the length of the guide bar.

While working make sure there is enough chain oil in the tank. If necessary, add oil.

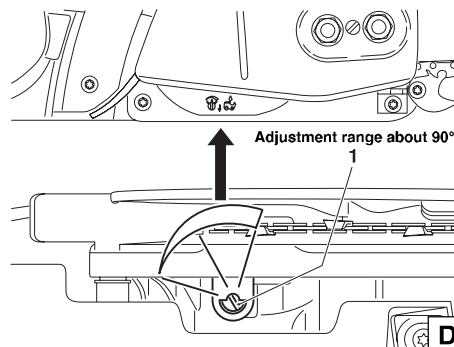

D

To ensure troublefree operation of the oil pump the oil guide groove at the crank case (2) and the oil inlet bore in the guide bar (3) must be cleaned regularly.

Note:

After the saw has been turned off it is normal for residual chain oil to drip from the oil feed system, the guide bar and the chain for a time. This does not constitute a defect!

Place the saw on a suitable surface.

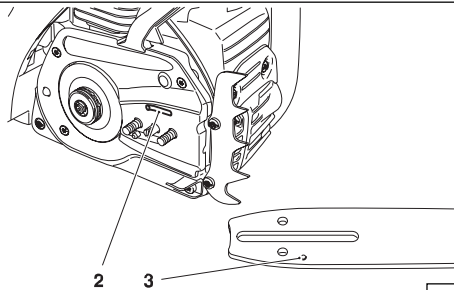

E

Starting the engine

Do not start the chain saw until after it is completely assembled and checked!

Move at least 3 meters / 10 feet away from the place where the chain saw was fuelled.

Make sure you have a secure footing, and place the saw on the ground in such a way that the guide bar and chain are not near anything.

Actuate the chain brake (block it).

Hold the front handle firmly with one hand and press the saw against the ground.

Hold the down rear handguard with your right foot as shown.

A

Cold starting:

Move the combination switch (1) up (choke position). This also actuates the half-throttle lock.

Pull the starter cable (2) out slowly until you feel resistance (the piston is now just before top dead centre).

Push in decompression valve (5) (only on DCS5031).

Now pull it quickly and powerfully until you hear the first audible ignition.

CAUTION: Do not pull the starter cable more than about 50 cm/20" out, and let it back in slowly by hand.

Push in decompression valve (5) (only on DCS5031).

Move the combination switch (1) to the central "ON" position. Pull the starter cable again, quickly and firmly. As soon as the engine is running, grasp the rear handle (the safety lock button (3) is actuated by the palm of the hand) and press the throttle trigger (4).

The half-throttle lock will disengage and the engine will now idle.

CAUTION: The engine must be put in idle immediately after starting. If this is not done, the clutch can be damaged.

Now disengage the chain brake.

Warm starting:

As described above for cold starting, but before starting push the combination switch (1) up (Choke position) and then right away back to the middle "ON" position. This is only to engage the half-throttle lock. If the engine doesn't start after 2 or 3 pulls, repeat the entire starting procedure as described for cold starting.

Stopping the engine

Depress the combination switch **STOP** (1).

NOTE: After being pressed down, the combination switch will revert to the ON position again. The engine is switched off, but can be turned on again without moving the combination switch.

IMPORTANT: To cut off the ignition current, push the combination switch all the way down past the resistance point to the safety position (⊕).

Combination switch in safety position
(ignition current cut off, necessary for all maintenance, repair, and installation work)

B

Checking the chain brake

The chain brake must be checked before every use of the saw!

Start the engine as described above (have a secure footing, place the chain saw on the ground so that the chain and guide bar are not near anything).

Hold the front handle firmly, with your other hand on the rear grip.

Let the engine run at medium speed and push the handguard (6) in the direction of the arrow using the back of your hand, until the chain brake engages. The chain should now stop immediately.

Bring the engine back to idle and release the chain brake.

Caution: If the chain does not stop immediately in this test, turn off the engine immediately. Do NOT use the chain saw in this condition! Contact a MAKITA service centre.



Working in winter

In order to prevent carburetor icing in conditions of low temperature combined with high humidity, and below + 5°C in order to get up to operating temperature faster, heated air can be taken from the cylinder.

Remove the cover (see "Cleaning the air filter").

Remove the insert (7) and insert it as shown for winter operation.

If the temperature is above + 5°C (40°F) the engine needs to induct cold air. **If this is not done, the cylinder and piston can be damaged!**

For temperatures above + 5°C (40°F) turn the insert 180° so that after it is inserted the induction opening (8) is closed.

Put the cover back on.

Note: When working in snow, the insert (7) can be replaced by a special insert with nylon screen, which prevents snow from getting in. It is available as an accessory, part no. 957 173 250.

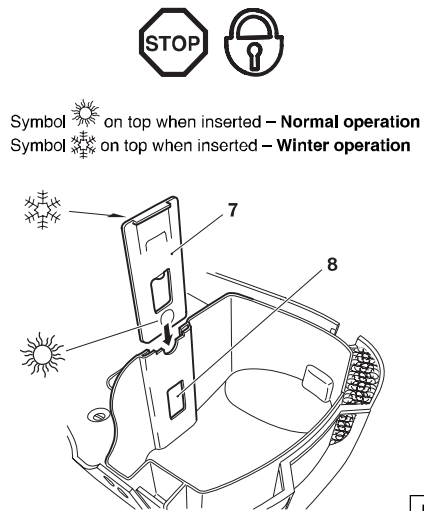

Grip heating

(only on "DCS5032" model saws)

The electric grip heating is switched on and off with switch (9).

On: Move switch down

Off: Move switch up

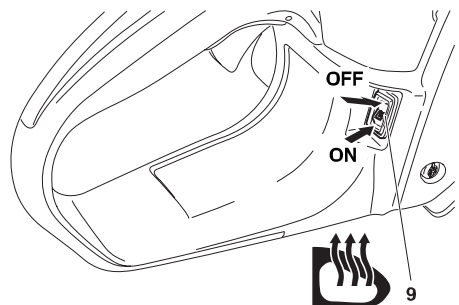

Adjusting the carburetor



CAUTION:

Do not adjust the carburetor until the machine has been completely assembled and checked! Do not adjust the carburetor without a tachometer!

Carburetor adjustment is necessary for optimum engine performance, for safer and more economical operation. Adjust the carburetor only with the engine warm, a clean air filter, and properly installed cutting tool.

Carburetor adjustment may be done only by a MAKITA service centre. Improper adjustment can cause damage to the engine.

In order to comply with new emissions legislation, limits have been placed on the carburetor adjusting screws (H) and (L).

This limitation (to about 180 degrees) prevents an excessively rich mixture. This in turn ensures compliance with emissions rules as well as optimum engine performance and economical fuel consumption.

You will need a tachometer (part No. 950 233 210) for optimum adjustment. Exceeding the maximum permissible speed can lead to overheating and under-lubricating, and damage to the engine!

Factory setting of adjusting screws (H) and (L): Turned out almost all the way (counterclockwise).

Use a screwdriver (blade width 4 mm, part No. 944 340 001) to adjust the screws.

For proper adjustment, proceed as follows:

Checking adjusting screw (H)

Before starting the engine make sure that adjusting screw (H) is turned out counterclockwise until it reaches a noticeable stop. The limitations do not prevent excessively lean running!

1. Start engine and let it warm up (3-5 minutes)
2. Set idle
3. Check acceleration
4. Set maximum permissible speed
5. Check idle speed

2. Set idle

Set the idle speed per the technical specifications.

Turning the adjusting screw (S) in (clockwise) increases the idle speed. Turning it out (counter-clockwise) lowers the idle speed. The cutting tool must not rotate!

3. Check acceleration

When the throttle is pressed, the engine should go smoothly from idle to high speed.

Turn adjusting screw (L) out (counterclockwise) in small increments until acceleration is good.

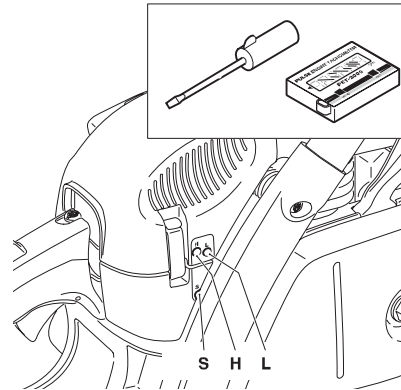

4. Set maximum permissible speed

Set the maximum speed by minimal adjustments of the adjusting screw (H) in accordance with the technical specifications. Turning the adjusting screw (H) clockwise increases the speed. **Never exceed the maximum permissible speed!**

For units with electronic engine speed limitation: **No tachometer is necessary to determine the maximum permissible speed, since exceeding this speed will result in clearly audible ignition misses!**

5. Check idle speed

Check the idle speed after setting the top speed (the cutting tool must not rotate!).

Repeat the adjustment procedure starting at Step 2, until the engine runs with the correct idle speed, good acceleration, and maximum permissible speed.

MAINTENANCE

Sharpening the saw chain

CAUTION: Before doing any work on the guide bar or chain, always switch off the engine and pull the plug cap off the spark plug (see „Replacing the spark plug“). Always wear protective gloves!

The chain needs sharpening when:

The sawdust produced when sawing damp wood looks like wood flour.

The chain penetrates the wood only under great pressure.

The cutting edge is visibly damaged.

The saw is pulled to the left or right when sawing. This is caused by uneven sharpening of the chain.

Important: Sharpen frequently, but without removing too much metal!

Generally, 2 or 3 strokes of the file will be enough.

Have the chain resharpened at a service centre when you have already sharpened it yourself several times.

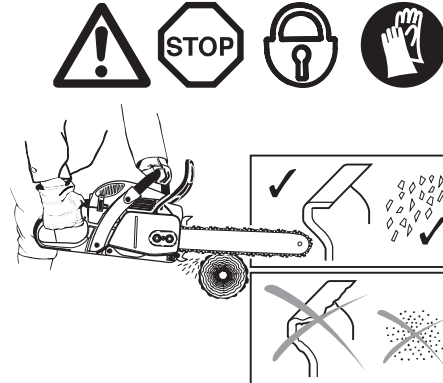

A

Proper sharpening:

CAUTION: Use only chains and guide bars designed for this saw (see the Extract from the spare-parts list)!

All cutters must be of the same length (dimension a). Cutters with different lengths result in rough running of the chain and can cause cracks in the chain.

The minimum cutter length: 3 mm. Do not resharpen the chain when the minimum cutter length has been reached; at this point, the chain must be replaced (see the Extract from the spare-parts list and „Replacing the saw chain“).

The depth of the cut is determined by the difference in height between the depth limiter (round nose) and the cutting edge.

The best results are obtained with a depth-limiter depth of 0.64 mm (.025“).

CAUTION: Excessive depth increases the risk of kickback!

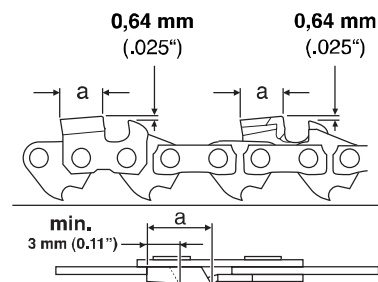

B

The sharpening angle (α) must be identical for all cutters!

25° for chain type 686, 099

30° for chain type 086, 484

35° for chain type 093

The teeth will have the proper angle (b) automatically if the proper round file is used.

60° for chain type 686, 099

85° for chain type 086, 093, 484

Different angles result in a roughly, irregularly running chain, increase wear and tear and cause chain beakage.

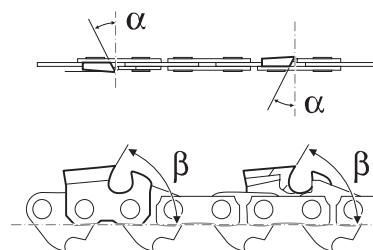

C

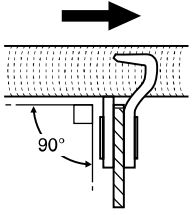

Chain typ
093

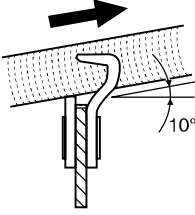

Chain typ
086, 686, 484
099

Files and how to work with them

Use a special saw chain round file for sharpening. Standard round files are unsuitable. For the order number, see "Accessories".

Type 086, 484, 686: File the first cutter half with a 4,8 mm dia. round saw-chain file, then switch to a 4.5 mm dia. file.

Type 093, 099: File the first cutter half with a 5,5 mm dia. round saw-chain file, then switch to a 4.5 mm dia. file.

The file should cut only when pushed forwards (arrow). Lift the file when leading it backwards.

First sharpen the shortest cutter. The length of this cutter is then the standard for all other cutters of the chain.

New saw teeth must be filed to the exact same shape as the used teeth, including on their running surfaces.

File depending on chain type (90° or 10° to the guide bar).

D

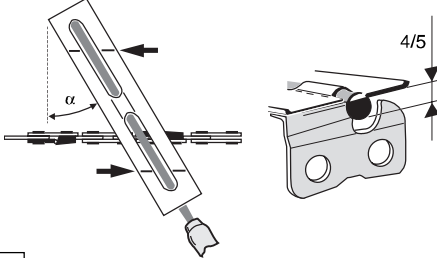

A file holder makes file guidance easier. It is marked for the correct sharpening angle of:

- $\alpha = 25^\circ$
- $\alpha = 30^\circ$
- $\alpha = 35^\circ$

(Keep the marks parallel with the chain when filing, see illustration) and limits the cut depth to the correct 4/5 of the file diameter. See "Accessories" for the order number.

E

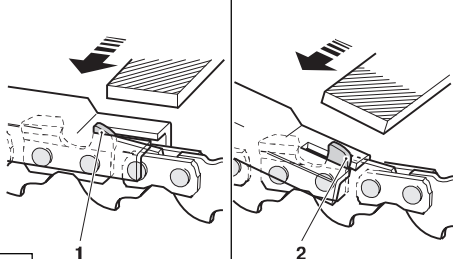

After having sharpened the chain, the height of the depth limiter must be checked by means of a chain gauge. See „Accessories“ for the order number.

Correct even the smallest excess height with a special flat file (1). See „Accessories“ for the order number.

Round off the front of the depth limiter (2).

F

Cleaning the brake band and sprocket interior

CAUTION: Before doing any work on the guide bar or chain, always switch off the engine and pull the plug cap off the spark plug (see „Replacing the spark plug“). Always wear protective gloves!

CAUTION: Start the chain saw only after having assembled it completely and inspected.

Remove the sprocket guard (1) (See „PUTTING INTO OPERATION“ figs. B) and clean the interior with a brush.

Turn the chain tensioning screw (2) to the left (counter-clockwise) until pin (3) of the chain tensioner is underneath the threaded pin (4).

Remove the chain (5) and guide bar (6).

NOTE:

Make sure there are no residues or foreign matter remaining in the oil guide groove (7) or on the chain tensioner (3).

For replacing the guide bar, chain, and sprocket see „PUTTING INTO OPERATION“.

NOTE:

The chain brake is a very important safety device and like any other component subject to normal wear and tear.

Regular inspection and maintenance are important for your own safety and must be done by a MAKITA service centre.

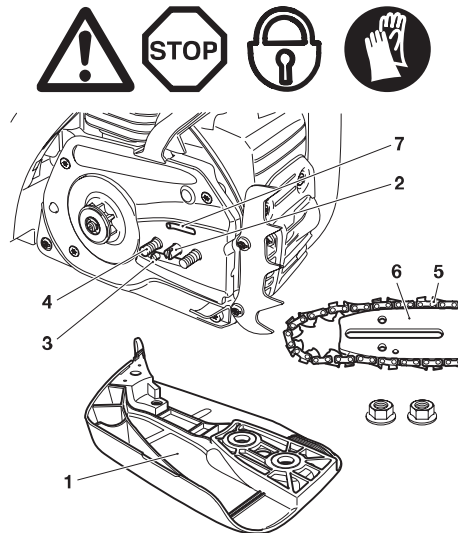

A

Cleaning the guide bar

CAUTION: Protective gloves must be worn.

Regularly inspect the bearing surfaces of the guide bar for damage, and clean them with a suitable tool.



B

Replacing the saw chain

CAUTION: Use only chains and guide bars designed for this saw (see the Extract from the spare-parts list)!

When changing chain types, always make sure to use the right sprocket (12). It may be necessary to change the sprocket.

IMPORTANT: If the chain type is changed from .325" to 3/8", the chip deflector must be modified. See under „Instructions for changing the chain type.“

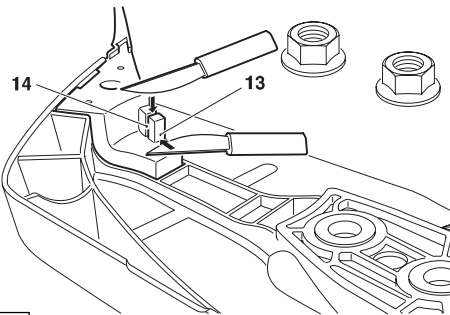
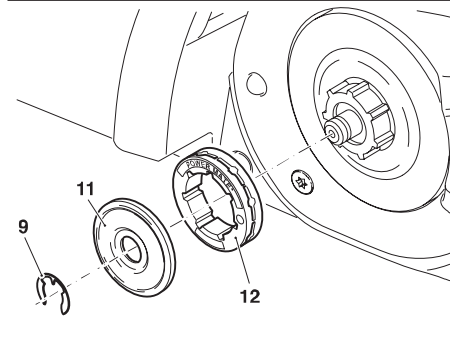
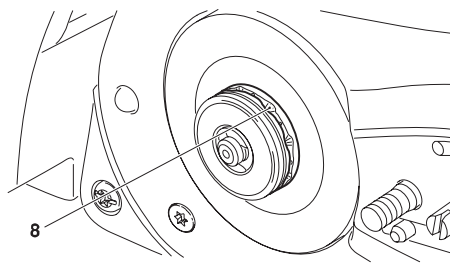

Check the sprocket before mounting a new chain.

Worn out sprockets (8) may damage the new chain and must therefore be replaced.

Remove the sprocket guard (See „PUTTING INTO OPERATION“ figs. B).

Remove the chain and guide bar.

Remove circlip (9).

CAUTION: The circlip will pop out of the groove. When removing it, hold your thumb against it to prevent it from popping off.

Remove thrust washer (11).

Replace the old sprocket (8) with a new one (12). For the part number consult the “Extract from the spare parts list”.

Put on a new sprocket, the thrust washer, and a new circlip (9) (for the order number see “Extract from the spare parts list”).

For replacing the guide bar, chain, and sprocket see „PUTTING INTO OPERATION A-H“.

NOTE:

Don't use a new chain on a worn chain sprocket. By the time 2 chains have worn, the sprocket has become worn out, so it should be replaced at least at every second chain replacement. To distribute the chain oil evenly, run a new chain at half-throttle for a few minutes before use.

New chains stretch, so check the chain tension frequently (see “Checking the chain tension”).

Likewise, replace the clutch drum at every second chain sprocket replacement.

Instructions for changing the chain type

Always wear protective gloves!

- Before using a 3/8" saw chain, be sure to first cut out the marked section of the chip deflector (13)!
- To do this, first cut along the marking (14) with a sharp knife and then cut across to remove the piece.

NOTE:

If switching to chain type .325" it will be necessary to install a new chip deflector (see „Extract from the spare parts list“ for the part number).

C

Cleaning the air filter



CAUTION: To prevent eye injury, always wear eye protection when cleaning the filter with compressed air!

Do not use fuel to clean the air filter.

Disengage the cover clasp (1) with the universal wrench and take off the cover (2).

Push up the combination switch (3) (Choke position) to prevent dirt particles from falling into the carburetor.

Unhook the clasp (4) in the direction of the arrow with a finger or the universal wrench.

Pull the air filter (5) up and out.

Take the pre-filter (5a) out of the cover (2).

IMPORTANT: Cover the intake opening with a clean cloth to prevent dirt particles from getting into the carburetor.

Choosing the right filter: The fleece filter is for use in dry or dusty conditions. The nylon filter (available as accessory) is for use in damp conditions. The pre-filter keeps out sawdust, and prevents powder snow from getting in when working in winter.

Pry apart the top and bottom of the air filter as shown in Figure.

Cleaning the fleece filter: Carefully tap out dust or carefully blow out dust from the inside with compressed air. Do not brush the fleece, as this will force dirt particles into the fabric. If the filter is very dirty, it can be washed in lukewarm water with regular dishwashing detergent. Note that the fleece filter does not need to be cleaned until there is a noticeable loss of power. If cleaning the filter does not bring an improvement in performance, it is time to replace it.

Cleaning the nylon filter: Use a soft brush or blow out dirt from the inside with compressed air. If the filter is very dirty, it can be washed in lukewarm water with regular dishwashing detergent. Clean frequently (several times a day) when working in very dusty or dirty conditions. Full engine power is possible only with a clean air filter!

Cleaning the pre-filter: When the pre-filter becomes dirty, wash it in lukewarm soapy water using standard dishwashing liquid.

Let the air filter **dry completely**.

Put the top and bottom sections back together.

Place the pre-filter back in the cover.

Before assembling the air filter, check the choke flap for any dirt particles. If there are any, remove them with a brush.

CAUTION: If the air filter becomes damaged, replace immediately! Pieces of cloth or large dirt particles can destroy the engine!

Insert the air filter (5) and press the clasp (4) in the direction of the arrow until it engages.

Move the combination switch (3) down and press the throttle (6) once all the way, to deactivate the half-throttle lock.

Put the cover (2) back on and affix it with the cover clasps (1).

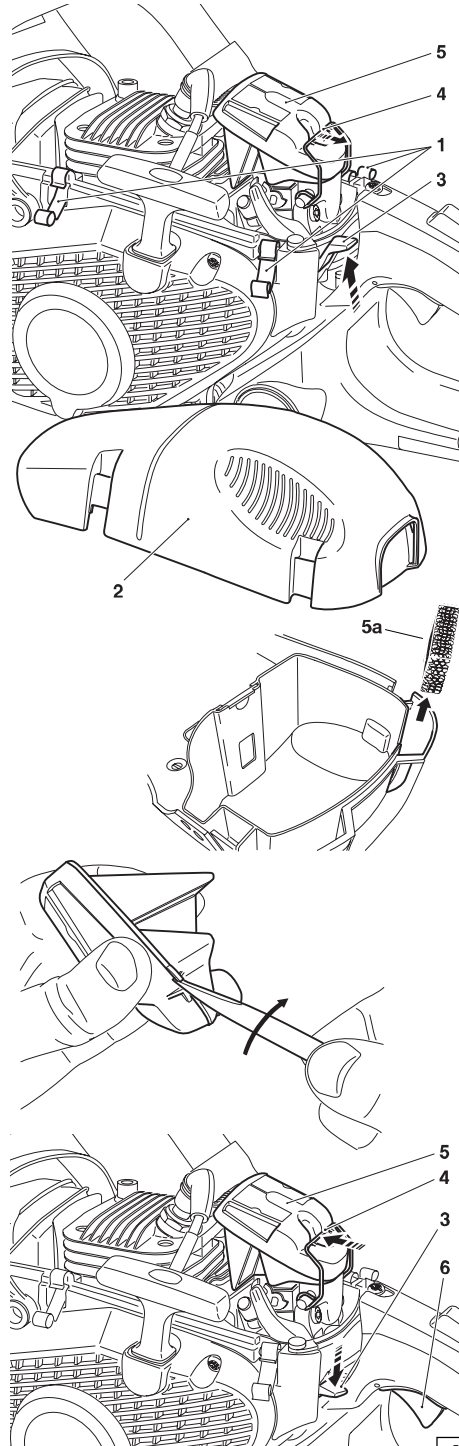

A

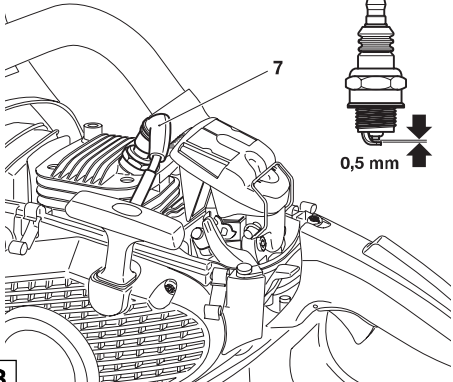
B

Replacing the spark plug

CAUTION:
Do not touch the spark plug or plug cap if the engine is running (high voltage).
Switch off the engine before starting any maintenance work. A hot engine can cause burns. Wear protective gloves!

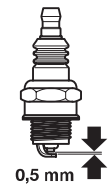

The spark plug must be replaced in case of damage to the insulator, electrode erosion (burn) or if the electrodes are very dirty or oily.
Remove the filter cover (see „Cleaning the air filter“).
Pull the plug cap (7) off the spark plug. Use only the combination wrench supplied with the saw to remove the spark plug.

Electrode gap
The electrode gap must be 0.5 mm.

CAUTION: Use only the following spark plugs: NGK BPMR 7A or BOSCH WSR 6F.

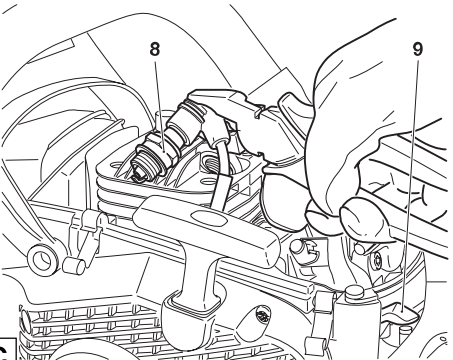

C

Checking the ignition spark



With the spark plug removed and the spark plug cap firmly seated, use insulated pliers to hold the spark plug (8) against the cylinder (not the spark plug hole).
Put combination switch (9) in the ON position.
Pull the starter cable hard.
If the function is correct, an ignition spark must be visible near the electrodes.

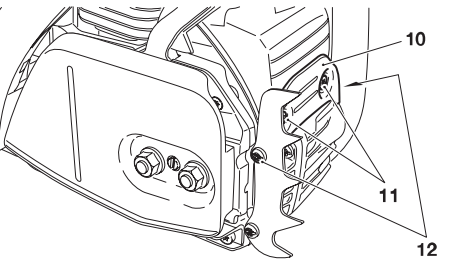

D

Checking the muffler screws



Remove the retaining plate (10) by unscrewing screws (11, short) and (12, long).
The muffler screws are now accessible through the blind holes and can be checked for tight fit. If they are loose, hand-tighten them (Important - do not overtighten!).

Replacing the starter cable/ Replacing the return spring pack/ Replacing the starter spring

Unscrew four screws (1).
Remove fan housing (2).

Remove the air guide (3) from the fan housing.

CAREFUL! Injury hazard! Do not unscrew screw (7) if the return spring is under tension.

If the starter cable is to be replaced although it is not broken, it will be necessary to first de-tension the cable drum return spring (13).

To do this, use the grip to pull the cable all the way out of the fan housing.

Hold the cable drum with one hand, and with the other push the cable into the space (14).

Carefully let the drum turn until the return spring is no longer under tension.

Unscrew screw (7) and remove the driver (8) and spring (6).

Carefully remove the cable drum.

Remove any cable pieces.

Thread a new cable (dia. 3.5 mm, length 1100 mm) as shown in the illustration (don't forget the washer (10)) and knot both ends as shown.

Pull knot (11) into the cable drum (5).

Pull knot (12) into the starter grip (9).

Put the drum on its spindle and turn it slightly until the return spring engages.

Place the spring (6) in the driver (8) and place them together in the cable drum (5) while turning slightly counter-clockwise. Insert screw (7) and tighten.

Guide the cable into the slot (14) on the cable drum and turn the drum with the cable clockwise three times.

Hold the cable drum with your left hand and with your right hand untwist the cable, pull it tight and hold it.

Carefully release the cable drum. The spring will wind the cable around the drum.

Repeat the procedure once. The starter grip should now stand straight up on the fan housing.

NOTE: With the cable pulled all the way out, it must still be possible to turn the pulley another 1/4 turn against the return spring.

CAUTION: Danger of injury! Secure the cable grip when pulled out! It will whip back if the cable pulley is released by accident.

Replacing the return spring pack

Disassemble the fan housing and cable drum (see above).

CAREFUL! Injury hazard! The return spring can pop out! Always wear eye protection and protective gloves!

Lightly tap the fan housing on a wooden surface with the entire surface of the hollow side, and hold it down. Now lift the fan housing carefully and in small steps. This will allow the return spring pack (13), which should now have fallen out, to relax in a controlled manner if the return spring has popped out of the plastic pack.

Carefully insert a new return spring cassette and press down until it engages.

Place the cable drum on it and turn it slightly until the return spring engages.

Install the spring (6) and driver (8) and screw on tight with screw (7).

Tension the spring (see above).

Replacing the starter spring

NOTE: If the spring (6) in the Featherlight-Starting system is broken, more effort will be required to start the engine and you will notice some resistance when pulling the starter cable. If you notice this, check the spring (6) and replace if necessary.

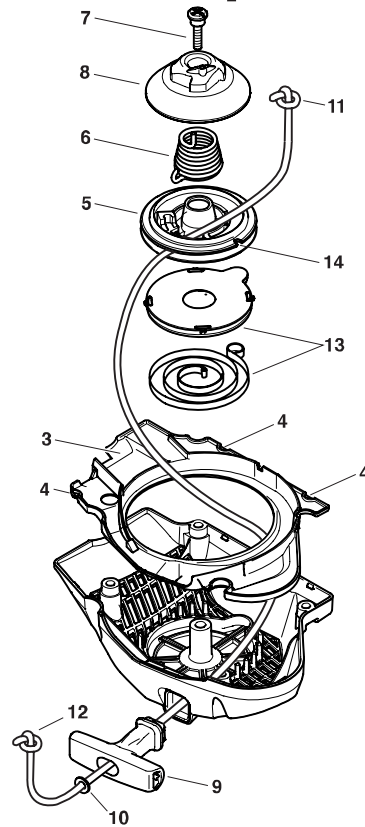
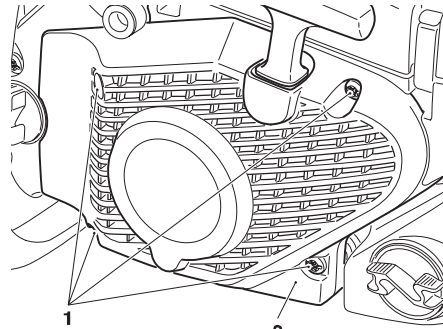

Mounting the fan housing

Insert the air guide (3) in the fan housing so that the three recesses (4) engage.

Position the fan housing against the housing, press against it lightly and pull the starter grip until the starter engages.

Tighten screws (1).

A

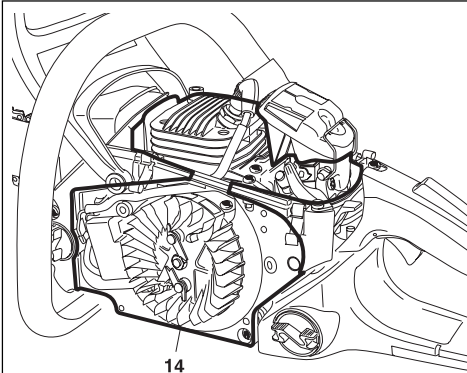

Cleaning the cylinder area



After prolonged use, dirt and sawdust can build up on the cylinder and cause the engine to overheat. The cylinder fin cleaner helps remove deposits between the cylinder fins and between the cylinder and the mounting plate.

Remove cover.
Remove the fan housing.

CAUTION: To prevent eye injury, always wear eye protection when cleaning the filter with compressed air!

The entire area (14) can now be brushed clean or cleaned with compressed air.
With the cylinder fin cleaner, clean out the area between the cylinder fins and between the cylinder and the mounting plate.
Do not use force. Be careful not to damage the short-circuit wire and the ignition wire.

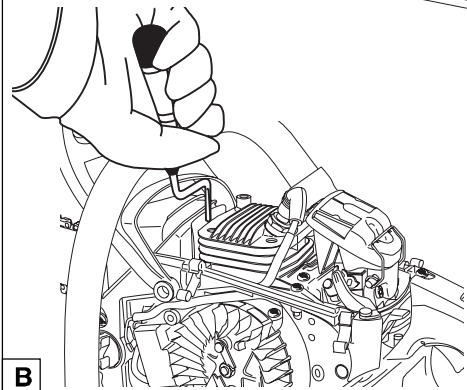
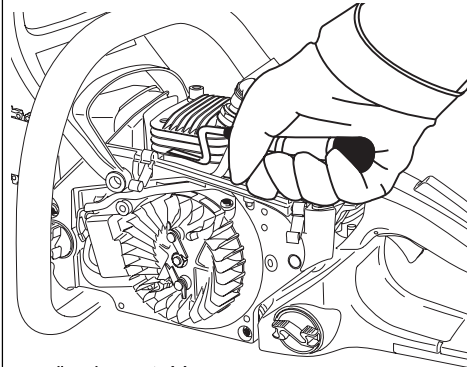

B

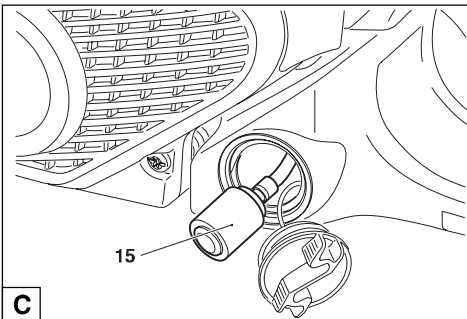

Replacing the suction head



The felt filter (15) of the suction head can become clogged. It is recommended to replace the suction head once every three months in order to ensure unimpeded fuel flow to the carburetor.

To remove the suction head for replacement, pull it out through the tank filler neck using a piece of wire bent at one end to form a hook.

C

Instructions for periodic maintenance

To ensure long life, prevent damage and ensure the full functioning of the safety features the following maintenance must be performed regularly. Guarantee claims can be recognized only if this work is performed regularly and properly. Failure to perform the prescribed maintenance work can lead to accidents!

The user of the chain saw must not perform maintenance work which is not described in the instruction manual. All such work must be carried out by a MAKITA service centre.

			Page
General	Chain saw	Clean exterior, check for damage. In case of damage, have repaired by a qualified service centre immediately	
	Saw chain	Sharpen regularly, replace in good time	19-12
	Chain brake	Have inspected regularly at an authorized service centre	
	Guide bar	Turn over to ensure even wear of bearing surfaces Replace in good time	12, 21
	Starter cable	Check for damage. Replace if damaged.	25
Before each start	Saw chain	Inspect for damage and sharpness Check chain tension	19-20 12
	Guide bar	Check for damage	
	Chain lubrication	Functional check	15
	Chain brake	Functional check	17
	Combination switch, Safety locking button, Throttle lever	Functional check	17
	Fuel/oil tank cap	Check for tightness	
Every day	Air filter	Clean (several times daily if necessary)	23
	Guide bar	Check for damage, clean oil intake bore	21
	Guide bar support	Clean, in particular the oil guide groove	15, 21
	Idle speed	Check (chain must not run)	18
Every week	Fan housing	Clean to maintain good cooling air flow.	9
	Cylinder area	Clean to maintain good cooling air flow.	26
	Spark plug	Check and replace if necessary	24
	Muffler	Check tightness of mounting, Check screws	9, 24
	Chain guide	Check	11
	Screws and nuts	Check their condition and that they are firmly secured.	
Every 3 months	Suction head	Replace	26
	Fuel, oil tanks	Clean	
Annually	Chain saw	Check at an authorized service centre	
Storage	Chain saw	Clean exterior, check for damage. In case of damage, have repaired by a qualified service centre immediately	
	Guide bar/chain	Demount, clean and oil slightly Clean the guide groove of the guide bar	21
	Fuel, oil tanks	Empty and clean	
	Carburetor	Run empty	

Service, spare parts and guarantee

Maintenance and repair

The maintenance and repair of modern engines as well as all safety devices require qualified technical training and a special workshop equipped with special tools and testing devices.

Any work not described in this Manual may be performed only by a MAKITA service centre.

The MAKITA service centres have all the necessary equipment and skilled and experienced personnel, who can work out cost-effective solutions and advise you in all matters.

Repair attempts by third parties or unauthorized persons will void all warranty claims.

Spare parts

Reliable long-term operation, as well as the safety of your chain saw, depend among other things on the quality of the spare parts used. Use only original MAKITA parts, marked 

Only original spare parts and accessories guarantee the highest quality in material, dimensions, function and safety.

Original spare parts and accessories can be obtained from your local dealer. He will also have the spare part lists to determine the required spare part numbers, and will be constantly informed about the latest improvements and spare part innovations. To find your local distributor, please visit www.makita-outdoor.com

Please bear in mind that if parts other than original MAKITA spare parts are used, this will automatically invalidate the MAKITA product guarantee.

Guarantee

MAKITA guarantees the highest quality and will therefore reimburse all costs for repair by replacement of damaged parts resulting from material or production faults occurring within the guarantee period after purchase. Please note that in some countries particular guarantee conditions may exist. If you have any questions, please contact your salesman, who is responsible for the guarantee of the product.

Please note that we cannot accept any responsibility for damage caused by:

- Disregard of the instruction manual.
- Non-performance of the required maintenance and cleaning.
- Incorrect carburetor adjustment.
- Obvious overloading due to permanent exceeding of the upper performance limits.
- Use of guide bars and chains which have not been approved.
- Use of guide bar and chain lengths which have not been approved.
- Use of force, improper use, misuse or accidents.
- Damage from overheating due to dirt on the fan housing.
- Work on the chain saw by unskilled persons or inappropriate repairs.
- Use of unsuitable spare parts or parts which are not original MAKITA parts, insofar as they have caused the damage.
- Use of unsuitable or old oil.
- Damages caused by disregarding loose outer bolted connections.

Cleaning, servicing and adjustment work is not covered by the guarantee. All repairs covered by the guarantee must be performed by a MAKITA service centre.

Trouble shooting

Malfunction	System	Observation	Cause
Chain does not run	Chain brake	Engine runs	Chain brake actuated.
Engine does not start or only with difficulty	Ignition system	Ignition spark No ignition spark	Malfunction in fuel supply system, compression system, mechanical malfunction. Switch on STOP, fault or short-circuit in the wiring, plug cap or spark plug defective. Combination switch in Choke position, carburetor defective, suction head dirty, fuel line bent or interrupted. Cylinder base packing ring defective, radial shaft packings defective, cylinder or piston rings defective Spark plug does not seal. Spring in starter broken, broken parts inside the engine.
	Fuel supply	Fuel tank is filled	
	Compression system	Inside	
	Mechanical malfunction	Outside Starter does not engage	
Warm start difficulties	Carburetor	Fuel tank is filled Ignition spark	Wrong carburetor adjustment.
Engine starts, but dies immediately	Fuel supply	Fuel tank is filled	Wrong idling adjustment, suction head or carburetor dirty. Tank venting defective, fuel line interrupted, cable defective, Combination switch defective, Decompression valve dirty
Insufficient power	Several systems may be involved simultaneously	Engine is idling	Air filter dirty, wrong carburetor adjustment, muffler clogged, exhaust channel in cylinder clogged, spark arrester screen clogged.
No chain lubrication	Oil tank/pump	No oil on the chain	Oil tank empty. Oil guide groove dirty. Oil-pump adjusting screw incorrectly adjusted.

EU Conformity Declaration

The undersigned, Tomoyasu Kato, as authorized by MAKITA Corporation, declare that the MAKITA machines,

Type: 180, 181

Chain saw EU prototype test certificate No.

DCS4630 (180) **M6T 09 10 24243 108**

DCS5030 (181) **M6T 09 10 24243 108**

DCS5031 (181) **M6T 09 10 24243 108**

DCS5032 (181) **M6T 09 10 24243 108**

manufactured by MAKITA Corporation, 3-11-8 Sumiyoshi-Cho, Anjo, Aichi, 446-8502 Japan, conforms to the basic safety and health requirements of the applicable EU Directives:

EU Machinery Directive 2006/42/EG, EU EMC Directive 2004/108/EG, Outdoor Noise Directive 2000/14/EG.

The most important standards applied to properly meet the requirements of the above EU Directive were: EN 11681-1, EN ISO 14982, CISPR 12.

The conformity assessment procedure 2000/14/EG was performed per Annex V. The measured noise level (L_{wa}) is 111 dB(A). The guaranteed noise level (L_d) is 112 dB(A).

The EU-Type-Examination Certificate was performed by: TÜV Product Service GmbH, Zertifizierstelle, Ridlerstr. 31, D-80339 München. The technical documentation is on file at MAKITA International Europe Ltd., Michigan Drive, Tongwell, Milton Keynes, Bucks, MK15 8JD, England.

Anjo, 4.11.2009

For MAKITA Corporation



Tomoyasu Kato
Managing Director

Extract from the spare parts list

Use only original MAKITA parts. For repairs and replacement of other parts, see your MAKITA service centre.

DCS4630, DCS5030
DCS5031, DCS5032

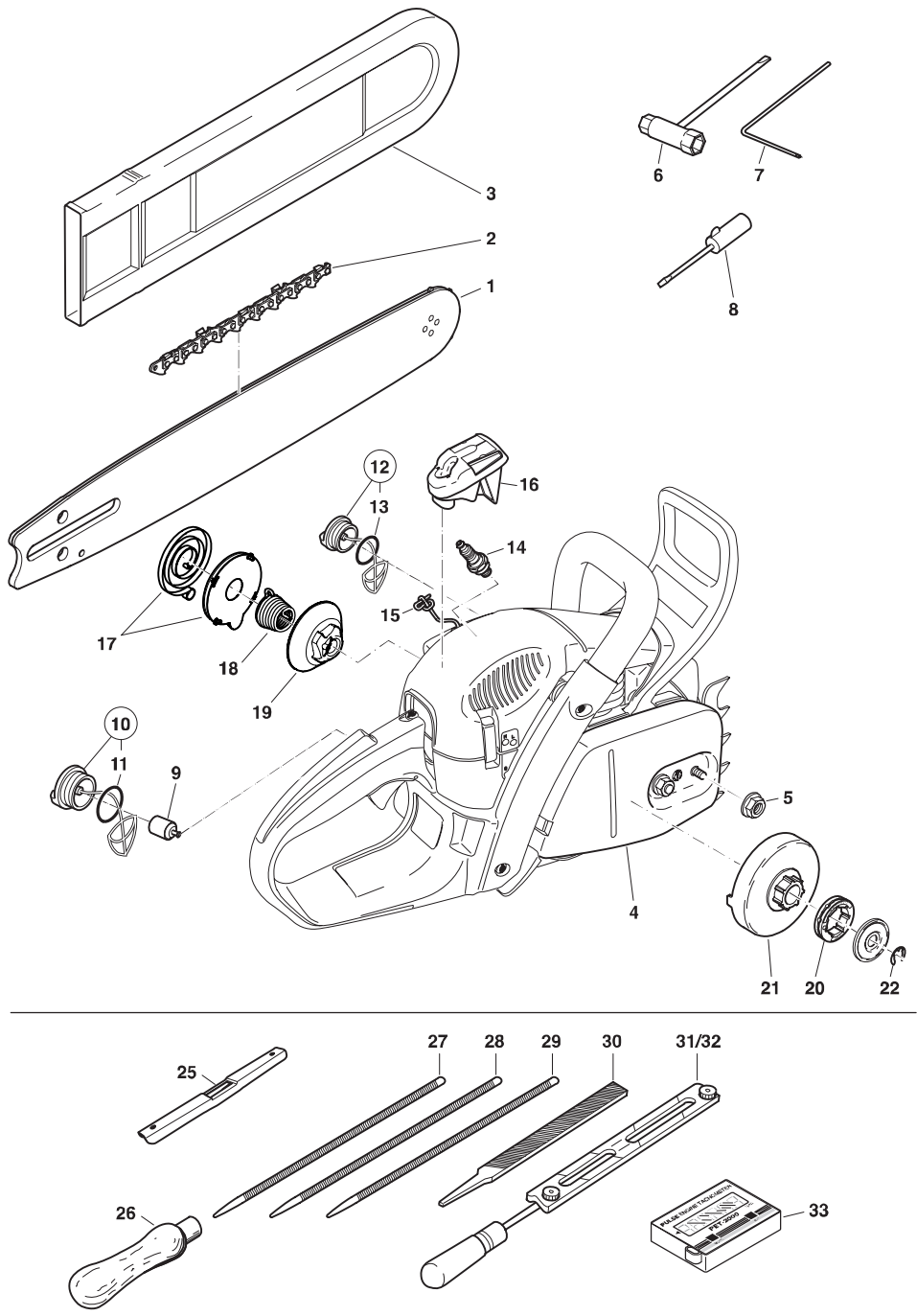

Extract from the spare parts list

Use only original MAKITA parts. For repairs and replacement of other parts, see your MAKITA service centre.

DCS4630, DCS5030
DCS5031, DCS5032

**Pos. MAKITA-No. Qty. Denomination**

1	445 033 631	1	Sprocket nose bar .325", 33 cm (13")
	445 038 631	1	Sprocket nose bar .325", 38 cm (15")
	445 045 631	1	Sprocket nose bar .325", 45 cm (18")
2	528 086 656	1	Saw chain .325" for 33 cm
	528 086 664	1	Saw chain .325" for 38 cm
	528 086 672	1	Saw chain .325" for 45 cm
2	534 686 056	1	Saw chain .325" for 33 cm
	534 686 064	1	Saw chain .325" for 38 cm
	534 686 072	1	Saw chain .325" for 45 cm
1	445 033 141	1	Sprocket nose bar .325", 33 cm (13")
	445 038 141	1	Sprocket nose bar .325", 38 cm (15")
	445 045 141	1	Sprocket nose bar .325", 45 cm (18")
2	532 484 056	1	Saw chain .325" for 33 cm
	532 484 064	1	Saw chain .325" for 38 cm
	532 484 072	1	Saw chain .325" for 45 cm
1	443 038 651	1	Sprocket nose bar 3/8", 38 cm (15")
	443 045 651	1	Sprocket nose bar 3/8", 45 cm (18")
	443 053 651	1	Sprocket nose bar 3/8", 53 cm (21")
2	528 099 656	1	Saw chain 3/8" for 38 cm
	528 099 664	1	Saw chain 3/8" for 45 cm
	528 099 672	1	Saw chain 3/8" for 53 cm
2	523 093 656	1	Saw chain 3/8" for 38 cm
	523 093 664	1	Saw chain 3/8" for 45 cm
	523 093 672	1	Saw chain 3/8" for 53 cm
3	952 010 630	1	Chain protector for 33-38 cm
	952 020 640	1	Chain protector for 45 cm
	952 020 650	1	Chain protector for 53 cm
4	181 213 601	1	Sprocket guard, cpl.
5	923 208 004	2	Hexagonal nut M8
6	941 719 131	1	Universal wrench SW 19/13
7	940 827 000	1	Offset screwdriver
8	944 340 001	1	Carburetor screwdriver
9	963 601 121	1	Suction head
10	181 114 202	1	Fuel tank cap, cpl.
11	963 229 036	1	O-Ring 29,3x3,6 mm
12	170 114 061	1	Oil tank cap, cpl.
13	963 225 030	1	O-Ring 25x3 mm
14	965 603 021	1	Spark plug
15	181 164 020	1	Starter cable 3,5x1100 mm
16	181 173 240	1	Air filter (nylon)
16	181 173 190	1	Air filter (fleece)
17	181 163 050	1	Return spring pack, complete
18	181 163 080	1	Spring
19	181 163 090	1	Driver
20	026 224 010	1	3/8" sprocket, (for 093, 099), 7-tooth
	181 224 040	1	Sprocket .325", (for 086, 484, 686) , 7-tooth
21	181 223 060	1	Clutch drum
22	927 408 000	1	Circlip

Accessories (not delivered with the chain saw)

25	953 100 090	1	Chain gauge
26	953 004 010	1	File handle
27	953 003 100	1	Round file, dia. 4,5 mm
28	953 003 070	1	Round file, dia. 4,8 mm
29	953 003 040	1	Round file, dia. 5,5 mm
30	953 003 060	1	Flat file
31	953 030 030	1	File holder 3/8"
32	953 030 030	1	File holder .325"
33	950 233 210	1	Tachometer
-	949 000 035	1	Combined can (for 5l fuel, 2,5l chain oil)

To find your local distributor,
please visit www.makita-outdoor.com



MAKITA Corporation
3-11-8 Sumiyoshi-Cho
Anjo, Aichi
446-8502 Japan

Specifications subject to
change without notice

Form: 995 705 232 (2.11 GB)